

CONTINUED SHEET 1

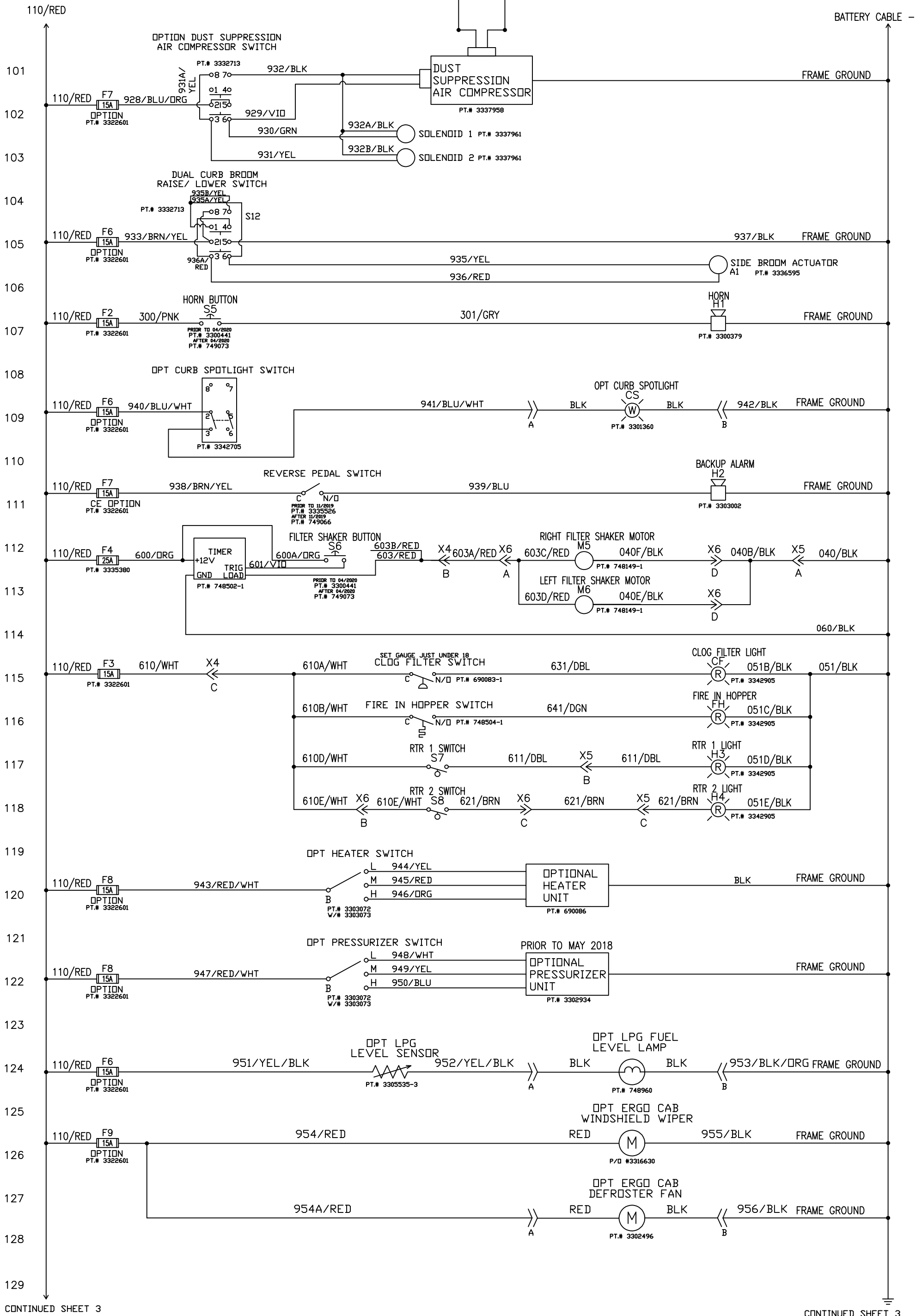

CONTINUED SHEET 3

CONTINUED SHEET 3

REV	ECN	DATE	DESCRIPTION	BY	PowerBoss The Power of Clean		CONFIDENTIAL THIS DRAWING AND ALL INFORMATION CONTAINED HEREIN ARE THE EXCLUSIVE PROPERTY OF MINUTEMAN INTERNATIONAL, INC. THIS DRAWING IS NOT TO BE COPIED OR OTHERWISE REPRODUCED WITHOUT EXPRESSED WRITTEN PERMISSION OF MINUTEMAN INTERNATIONAL, INC. IN ADDITION, THIS DRAWING MUST BE RETURNED UPON REQUEST. FURTHER, ALL INFORMATION CONTAINED HEREIN MUST BE MAINTAINED CONFIDENTIAL.		TITLE SCHEMATIC-ELECTRICAL 9X GAS/LPG CE		
D	150297	06/11/18	ADDED MERV, LED LIGHTS & SHT 4	KHH	14N845 U.S. ROUTE 20 PINGREE GROVE, ILLINOIS 60140				PART NUMBER	REVISION	PAGE NUMBER
E	150470	11/13/18	UPDATED MERV, PART #'S	KHH					3397502	G	2 OF 4
F	151016	11/08/19	REMOVE ENGINE CONN 1 PIN B WIRE	KHH	ELECTRICAL DESIGN ENGINEER Jeff Pollack		CAD BY JWP		DATE 5/3/10		
G	151310	04/20/20	UPDATE SEAT SWITCH	KHH							